

VBK 611 Specifications

- Available in 2 colour options
- Heavy ceramic design
- Replicates farmhouse look

NB. Ceramic sinks may vary due to natural shrinkage

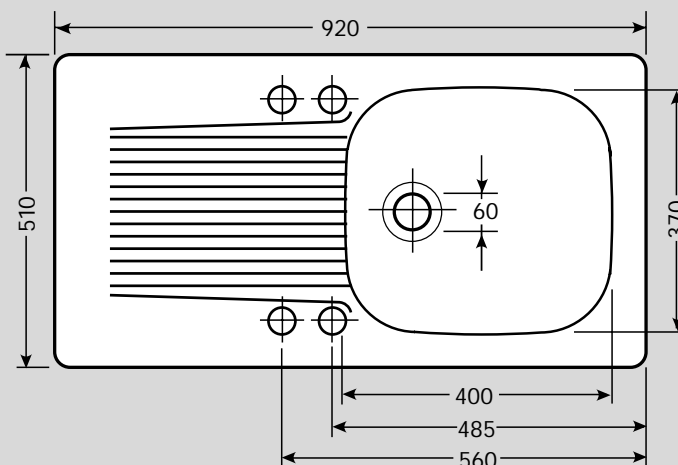

Materials: Fireclay Ceramic

Application: Inset

Bowl size: 400 x 370 x 160

Drainer Format: Reversible

Cut-out size: 880 x 460

Colour: White or Cappuccino

Seal: Not applicable

Insulation: Integral

Heat resistance: Up to 300°

Earthing Point: Not applicable

Cabinet size:

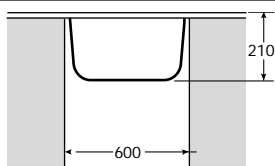

Fixing Clips: Utilise mastic

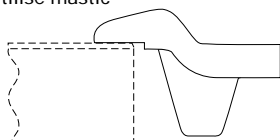

Suggested Plumbing Kit: 1 part (converter may be required)

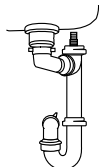

Waste: 1 x 60mm Basket Strainer Waste with overflow

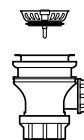

Overflow:



Accessories: Not available

Taps: Any Franke tap can be utilised with this model*.

*Ceramic disc taps in certain installations or where there is a low head of water (below 3 metres) may not provide adequate flow rates. You are advised to check with your supplier.

Guarantee: Franke sinks are guaranteed for 25 years against manufacturing defect. Franke taps are guaranteed against defective materials and workmanship for 1 year in relation to coatings and finishes, and 5 years in relation to moving parts. Franke will replace (and where appropriate repair) defective sinks. In relation to taps, Franke will where appropriate provide replacement parts for your taps or replace your taps. Any associated or ancillary costs to be incurred by you as a result of replacement of Franke sinks and taps under this guarantee shall in all cases be previously approved by Franke UK Limited.

This guarantee is in addition to and does not affect your statutory rights.